

Guide to the Chrysler 8-3/4"

Revised: 16 June 2004

This information is a sincere effort to impart a basic understanding of automobile technology. If, while attempting to apply any of the ideas, procedures or suggestions herein, you should experience any kind of automobile system failure, it will be as a result of your own conscious decision and actions. All authors of text found here, or anywhere on this site, disclaim responsibility for any reader's actions, and any damage, injury, or death that occurred or may occur based on information found herein. Before proceeding, please read our [disclaimer](#).

Part I of this guide was authored by Gary Lewallen (aka. Vaanth) for the MML and Internet community. It was originally published in January 1998. Part II was authored by Doug Ahern as a supplement to Part I.

A Chrysler 8-3/4" Rear Axle Guide Part I.

- Author: Gary Lewallen (aka. Vaanth)
- Date: 12 January 1998
- Updated: 20 January 2000

Introduction

The Chrysler 8-3/4" rear axle assembly was introduced in 1957. It is a banjo-type (Hotchkiss) axle, i.e. the differential is contained in a removable carrier assembly. The axle has an 8-3/4" diameter ring gear. There are three basic types available distinguished by their drive pinion stem diameter. The 8-3/4" axle was the primary axle assembly used in most car lines through 1972, and saw continued use until 1974.

8-3/4" Axle Center Section Types

The 8-3/4" axle was available in three basic types. The types are differentiated by the pinion stem diameter....1-3/8", 1-3/4", 1-7/8". The choice of axle pinion assembly was determined based on the application.

1-3/8" small stem pinion... (aka. '741')...

Carrier casting numbers: 1820657 (1957-1964), 2070741 (1963-1972). This assembly was typically used in low weight/low horsepower applications through low weight/medium horsepower and high weight/low horsepower applications. Pinion depth and bearing preload is set with shims. Differential bearing setting (i.e. backlash) is set with threaded adjusters.

1-3/4" large stem pinion... (aka. '742')...

Carrier casting numbers: 1634985 (1957-1964), 2070742 (~1961-1969). This assembly was replaced by a phase-in of the 1-7/8" pinion starting in the 1969 model year. 1970 RW (Plymouth and Dodge mid-size) were the last models to use the 1-3/4" which appeared in a 2881489 case. This assembly was typically used in high weight/medium horsepower applications through high weight/high horsepower applications. Pinion depth and bearing preload is set with shims. Differential bearing setting (i.e. backlash) is set with threaded adjusters.

1-7/8" tapered stem pinion... (aka. '489')...

Carrier casting numbers: 2881488, 2881489 (1969-1974). This assembly was introduced in 1969 and was phased-in as a replacement for both the 1-3/4" "742" unit and the 1-3/8" "741" unit. Note: the 1-3/4" pinion also appeared in some '489' carriers during this period. By 1973, the '489' was the only unit available in passenger car applications. This assembly was typically used in high weight/medium horsepower applications through high weight/high horsepower applications. Pinion depth is set with shims, preload is set with a crush sleeve. Differential bearing setting (i.e. backlash) is set with threaded adjusters.

All 8-3/4" carrier assemblies can be identified externally by the casting numbers. Additionally, the '741' commonly has a large X cast on the left side, the '742' may have a large 2 cast on the left side, and the '489' has a large 9 cast on the left side. Through 1965, the factory ratio was stamped on the identification boss, followed by an 'S' if Sure Grip equipped. After 1965, a tag was affixed under one of the carrier mounting nuts to identify the ratio. If Sure Grip equipped, an additional Sure Grip lube tag was sometimes affixed; later years sometimes had the filler plug painted orange.

Gear ratios available on the 8-3/4" axle through the years include: 2.76, 2.93, 3.23, 3.31, 3.55, 3.73, 3.91, 4.10, 4.56, 4.89, 5.17, 5.57. On OEM gear sets, the ratio is usually stamped on the ring gear edge. Ratio may be determined by the number of teeth on the ring gear divided by the number of teeth on the pinion gear or by counting the ratio of the number of turns of the pinion relative to one turn of the axle shaft.

The 8-3/4" center section is removed from the front of the housing. It is retained by 10 nuts on studs in the housing. The rear of the housing is smooth, the back is welded onto the main housing. The axle tubes are part of the overall housing. To remove the center section, remove the wheels, brake drums, and drive shaft (note: pre-1965 units have a pressed-on brake hub which requires a puller for removal -- *see Part II, Appendix B*). Remove the axle shafts and the five bolts on the backing plate flange on post 64 units (use puller for pressed-in pre-1965 units). Remove the ten nuts on the housing studs around the carrier perimeter then remove the carrier (which may require prying), fluid will drain when carrier gasket seal is broken.

Interchange Notes:

Any 8-3/4" center section may be interchanged for another as an entire assembly, with the exception of center sections manufactured prior to model year 1964 (See Part II, Section 1: "Thrust Block Variations").

Sure Grip

Sure Grip is the Chrysler name for a limited slip differential. It was optional on the 8-3/4" axles, 1958-1974. Two styles were used.

Dana Power-Lok

1958-1969 used the Dana Power-Lok (# 2881487). This unit utilized clutches for the differential locking action. The Power-Lok can be rebuilt using kit # 2070845 (Mopar Performance [MP] # P4529484). In this assembly, axle driveshaft end thrust is taken by the thrust block assembly (replacement # 2881313). This Sure Grip appeared in the '741' and '742' assemblies. The axle bearings are: 25590 (Timken cone), and 25520 (Timken cup), (Chrysler numbers 1790523 and 696403). The Dana Power-Lok can be recognized by its bolt-together assembly, bolts around the side opposite the ring gear, and multiple openings exposing the cross shafts.

Borg Warner Spin Resistant

1969-1974 used the Borg Warner Spin Resistant (# 2881343). This unit utilized a spring-preloaded cone friction arrangement for the locking action. Axle end thrust is taken by the cross shaft. This Sure Grip appeared in '489' assemblies and 70 and later '741'/'742' assemblies. The differential axle bearings are: LM 104912 (Timken cone), and LM 104949 (Timken cup), (Chrysler numbers 2852729 and 2852728). The Borg Warner Spin Resistant unit can be recognized by its lack of bolts on the side opposite the ring gear (like the Dana), and two openings exposing the preload springs. Borg Warner sold this design to Auburn Gear who currently offers the replacement Sure Grip assemblies.

Non-Sure Grip differentials can be identified by the large openings in the differential exposing the differential (aka. spider) gears. There are no springs or clutches.

Interchange Notes:

The two Sure Grip types can be interchanged between the carriers if the matching differential axle bearings are retained. The outside diameter of the cups are the same between the '741'/'742' and the '489'; the inner cone differs.

The Sure Grip differential can be used as a direct replacement for the non-Sure Grip within the carrier/bearing limits previously noted.

There is an interchange problem with differentials and axles manufactured prior to 1964 (See Part II, Section 1: "Thrust Block Variations").

Universal Joint Yokes

The 8-3/4" axle was offered with two size cross & roller style universal joint. These are referred to as the '7260' (2-1/8" yoke ID) and the '7290' (2-5/8" yoke ID). Most Imperials and some C-bodies used a different universal joint. The '1330' type joint was used on Imperials and others with a constant velocity joint. The '1330' uses outside snap rings instead of the inside snap rings used by the '7269' and '7290'. The cap diameter for the '7260' is 1.078". The cap diameter for the '7290' is 1.126". The '1330' style joint cap diameter is 1.063".

There are four different yokes that have been used with the 8-3/4" axle for the '7260' and '7290' style universal joints. The '741'/'742' assemblies used a coarse spline (10 splines) drive pinion. Most of the aftermarket gears also use this coarse spline yoke mount. There is a small yoke for the '7260' and a larger one for the '7290'. The '489' assembly used a fine spline (29 splines) yoke. Note: during the phase-in period of 69-71 for the '489' unit, there were several permutations of pinion size and yoke availability. 69-70 '489' units may be equipped with a coarse (10) spline pinion, particularly for the '7290'. There are two yokes for the '7260' and '7290' universal joints with fine (29) splines. Two additional yokes were used for the '1330' style universal joint in constant velocity applications, one for 10 splines and one for 29 splines.

Note: the axle centerline to yoke/universal centerline is 12.35" for the 8-3/4" axle.

Interchange Notes:

7260, 7290, 1330 yokes may be interchanged if the spline count is the same.

Note: the 9-1/4" axle (73-up) uses the same fine spline yokes as the 8-3/4" fine spline units (29 splines).

Strength Considerations

Pinions

The 1-3/8" '741' pinion is the weakest. It is still a capable unit in most moderate power, moderate traction street applications. For high torque applications with high traction tires, the 1-3/4" or 1-7/8" should be considered.

The 1-7/8" '489' is supposedly the strongest. Although the stem tapers down along its length, it appears inherently stronger from a pinion stem perspective and the inherent strength of the fine splines (OEM gears). The 1-3/4" '742' has a larger rear pinion bearing yielding greater strength in this area. The 1-3/4" shares yoke mount diameter and mounting nut with the 1-3/8".

For perspective, the 7-1/4" has a 1-3/8" pinion, the 8-1/4 has a 1-5/8" pinion, the 9-1/4" (70s) has a 1-7/8" pinion.

Sure Grips

The Dana Power-Lok is inherently stronger and provides better, equal torque transmission to both axles. It's locking capability is also proportionate to the applied torque. The Borg Warner unit is weaker, but is a more versatile unit for practical street applications in inclement traction periods. The Dana unit is better for racing applications and has clutch rebuild kits available.

Axle and Housing Notes

Because the 8-3/4" axle was available in most body lines, there are a variety of housings available. The 8-3/4 was also available in the 58-74 D100/W100 trucks (and variants), the 64-70 A-100 trucks and vans, the 67-70 A-108 trucks and vans, the 71-74 B100/B200 vans and non-listed 57-64 full and mid-size car models.

See Part II, Section 3: "Part Numbers and Dimensions of Axles and Housings" for axle housing part numbers, sizes, and more detailed interchange information of axles and housings.

Interchange Notes:

Any 8-3/4" center section may be interchanged for another as an entire assembly except for a thrust block difference of non-Suregrip units built before 1964 (See Part II, Section 1).

All 8-3/4" axle shafts, 65-74, are retained by a bolt-on flange. Axles can be interchanged within housings of the same width. The passenger side axle has a threaded adjuster to set axle shaft end play.

Note: there was a slight dimensional change in axle shaft length when the Sure Grip design changed. If interchanging axles with the slight difference, the threaded end play adjustment can be used to accommodate it.

Note: the 57-64 8-3/4 axle driveshafts were tapered and used a keyway and locknut to retain the brake assemblies and end play was set with shims. The 65 and later units use flanged axle shafts and a threaded adjuster to set axle end play.

See *Part I, Appendix A* for information about the A-body 8-3/4" axle and bolt circle changes.

Service Parts Information

Most replacement parts for the 8-3/4" axle are still available. Some items not available are new Dana Power-Lok assemblies, most OEM gears, most carrier housings and complete differentials and housings. Sure Grips are available from Auburn Gear. The Power-Lok clutch kits are available from MP and other sources. Gear sets (typically performance oriented ratios) are available from MP and the aftermarket for the '489' and '742'. Bearings and seals are readily available.

Some sources...

- Mopar Performance dealers, Chrysler dealers.
- Moser Engineering, 1616 Franklin St, Portland IN, 47371 (219-726-6689).
- Reider Racing, 12351 Universal Dr., Taylor MI, 48180 (313-946-8672).

Selected Parts Reference

Numbers listed for reference, some may be superseded or discontinued, some variances among models/years may occur. Reference factory or replacement parts catalogs for exact replacement details.

Universal Joint Items

Item (Detroit ref.)	Chrysler	Precision (Moog)	Dana (Spicer)	TRW (FederalMogul)
7260 joint	4364400	315G	5-1306X	20030, 20030P
7290 joint	4057025	316	5-1309X	20059, 20059P
Combination **	---	347	---	20226
1330 joint	2533202	354	5-213X	20064, 20064P
7260 strap kit	P4120468	318-10	2-70-38X	20704
7290 strap kit	P4120469	492-10	2-70-28X	20705

** This is a combination of the 7260 and 7290 universal joints to allow mating of the two styles.

Chrysler Part Numbers

Yoke Items		
	3432485	29 spline 7260 (2-1/8" ID), also P4529481
	3432487	29 spline 7290 (2-5/8" ID), also P4529483
	3004872	10 spline 7260 (2-1/8" ID), also P4529480
	P4529482	10 spline 7290 (2-5/8" ID), replaces 2808384, 3004873
	2931813	10 spline 1330, for constant velocity, i.e. Imperial.
	3432489	29 spline 1330, for constant velocity, i.e. Imperial.
	1556556	pinion washer, concave, 3/16" thick, 13/16" hole diameter.
	2070117	pinion washer, concave, 3/16" thick, 15/16" hole diameter.
	1795175	pinion washer, flat, 3/32" thick, 13/16" hole diameter.
	1795173	pinion nut, 3/4"-16 thread, 1-1/4" hex.
	6027323	pinion nut, 3/4"-16 thread, 1-1/8" hex.
	6028041	pinion nut, 7/8"-14 thread, 1-1/4" hex.
Sure Grip Items		
	4318060	Mopar Sure Grip axle additive.
	2881313	Dana Power-Lock thrust block set.
	P4529484	Repair Kit, Dana Power-Lok (replaces 2070845)
	N/A	Repair Kit, Borg Warner/Auburn unit. <i>see note below.</i>
Shim Packages		
	P4452027	1-3/4" pinion Shim Package
	P4452026	1-7/8" pinion Shim Package
Ring Gear Bolts		
	P4529486	71 and later (also 4131255, pkg. of 10)
	P5249163	70 and earlier, <i>see note below</i>
Miscellaneous		
	4032798	Vent bolt
	P4120074	Spring mounting pads (perches)
	2931687	'489' collapsible spacer (pinion bearing preload)
	4318058	Mopar gear lubricant
	4318060	Mopar Sure Grip axle additive
	4318064	Mopar wheel bearing lubricant

Note: there is no repair kit for the Borg Warner/Auburn unit, but the internal cones have been re-machined by others to successfully restore performance.

Note: the 71 and later bolts may be installed in the earlier units by drilling a shoulder relief in the attachment holes.

Gaskets and Seals

Position	Chrysler	National	C/R	Fel-Pro
Axle inner seal	4796698	8695S	15460	---
Axle outer seal	2404216	8704S	19000	---
Axle flange, foam	2070933	see flange kit	see flange kit	55032
Axle flange, shim	2881314	see flange kit	see flange kit	---
Carrier gasket	1673367	---	---	RDS 65833
Pinion seal, 1-7/8	2931862	5126	18708	---
Pinion seal, 1-3/4	2931862	7216	18912	---
Pinion seal, 1-3/8	2931862	8515N	18708	---
Yoke repair sleeve	---	99187	99187	---

Bearings

Position	Cup/Cone (Timken, BCA)	Notes
Differential, side	LM 104949/LM 104912	70-74, Borg Warner
Differential, side	25590/25520	57-69, Dana
Pinion, front	M88048/M88010	1-7/8"
Pinion, front	HM89443/HM89410	1-3/4"
Pinion, front	M88048/M88010	1-3/8"
Pinion, rear	M804049/M804010	1-7/8"
Pinion, rear	M803149/M803110	1-3/4"
Pinion, rear	HM89446/HM89410	1-3/8"

Axle Bearings

	Chrysler	BCA	C/R
Axle, outer; 64-74		A7	BR7
Axle mounting flange repair kit, right		A-7-RK	A7-RK
Axle mounting flange repair kit, left		A-7-LK	A7-LK
differential kit 1-7/8"		RA-301	
differential kit 1-3/4"		RA-300	
axle bearing service kit	3683966		

Part I, Appendix A: 8-3/4 A-body axle upgrade to 4.5" bolt circle

The 65-72 A-bodies were available with the 8-3/4" axle. This was standard on all 340 equipped cars. It was also included in heavy duty packages such as 318 with manual transmission and towing options. It was often included in post 65 273 high performance manual applications.

The bolt circle (BC) on these vehicles was 4". All other Chrysler vehicles (except some Imperials and trucks) of this era were equipped with a 4.5" BC. It is commonly desired by A-body owners to change to the 4.5" BC when upgrading to later style disk brakes or to expand wheel choice.

A-body 8-3/4" axle shaft swap:

There are several methods to accomplish this. Custom axles such as Strange, Summers, Moser, etc. can be specified with the larger lug pattern for the A-body housing. Longer axles from a larger vehicle may be cut and re-splined to fit the shorter A-body axle. Donors for this operation are C-bodies, D-bodies, trucks and vans with the 8-3/4" axle and 4.5" BC. Moser Engineering can perform the cut and re-spline operation. When selecting a donor axle shaft, look for one that does not taper along its length. Note: A-body 8-3/4" axles were equipped with 10x1-3/4" drum brakes. Replace these with 10x2-1/2" or 11-2-1/2" brakes and associated hardware from the donor vehicle or similar.

B-body axle in the A-body:

Another alternative can be used to replace an existing 8-3/4" or the smaller 7-1/4" or 8-1/4" axles. An axle from a 66-70 B-body can be installed in the A-body (note: a 62-64 axle can be used, but it does not contain the flanged axles of the later units). The later sport coupe style cars, Duster, Demon, Dart Sport, have the roomiest fender wells. The 67-76 sedan and hardtop models have less. The 60-66 appear to be the tightest fit. The A-body has a spring perch spacing of 43.0", the 66-70 B-body is 44.0". To mount the B-body axle on the A-body springs, the perches need to be removed and new ones welded in place 1/2" inward from the original location on each side. The B-body track width is greater than the A-body. This may be a concern depending on the wheel/tire combination.

The wider track enhances handling and aesthetics to some degree. This has been performed on the author's 73 Duster, now equipped with 15x6.5" rallye wheels and P255/60R-15 tires with 11x2.5" brakes. Originally setup with 15x7" rallye wheels and P275/60R-15 tires will rolled fender lips. The larger tires exhibited scrubbing when loaded on dips/bumps. If replacing a 7-1/4" or 8-1/4" axle, the driveshaft must be changed as the axle centerline to yoke centerline is greater for the 8-3/4" (12.35" vs. 10.09" for 7-1/4" and 11.69" for 8-1/4"). If changing a 7-1/4" axle the shock plates and u-bolts/nuts must be changed to the larger units from an 8-3/4" car.

A Chrysler 8-3/4" Rear Axle Guide, Part II

- Author: Doug Ahern

Section 1: Thrust Block Variations

There was a difference in thrust blocks prior to 1964 that make center section interchange, as well as axle interchange problematic. The thrust block, or "axle shaft thrust spacer", is the block that both left and right axles butt up against inside the center of the differential. Prior to 1964, all open differentials used a thrust block was approximately 1/8" to 1/4" thicker than units made after 1964. The Sure Grip thrust block prior to 1964, however, was identical to all 1964 and later Sure Grips and open differentials. In 1964, the thrust block width was changed to match the Sure Grip thrust block width.

This difference in thrust blocks between Sure Grip differentials and open differentials required that two different axles be produced for each 8-3/4" housing manufactured. This is true of all 1959-1963 cars with 8-3/4"s.

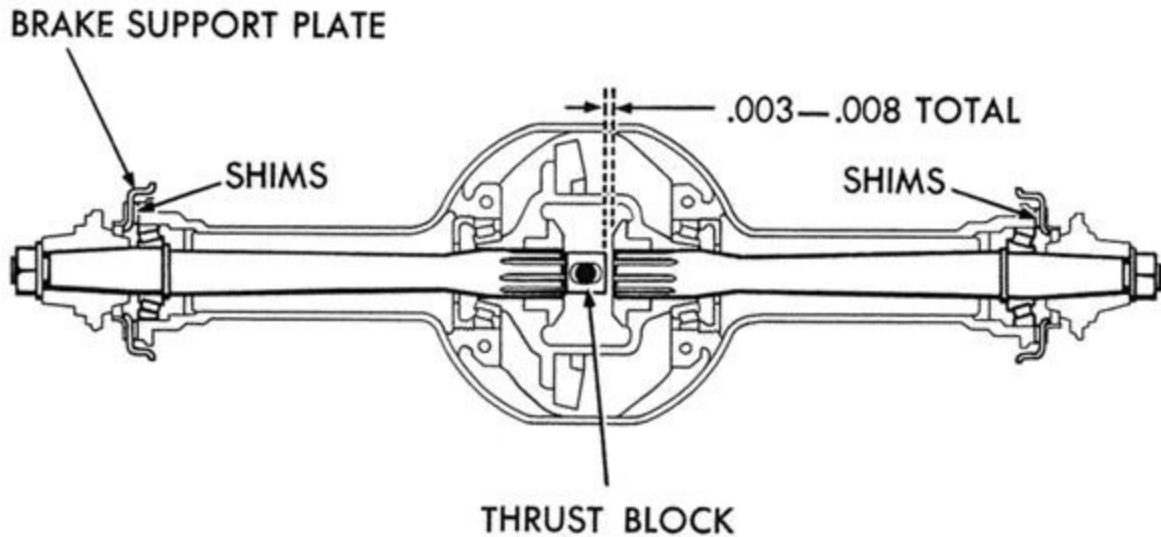

This diagram shows the location of the thrust block and makes it clear that if the width of this block changes, the axle lengths must change as well.

A 1964 and later differential, or any Sure Grip differential, cannot be used with 1959-1963 rear-ends and axles originally equipped with an open differential. The original axles must be machined or original Sure Grip length axles must be used.

Section 3 contains housing and axle sizes and part numbers for these early 8-3/4" rear-ends.

Section 2: Flange Axle Taper and Flange Differences

Besides the obvious bolt circle lug pattern difference between the A-body 4" BC axle and all other passenger car 4.5" BC axles, there is a sometimes unexpected difference in the flange that tends to cause confusion. The distance from the axle housing flange to the wheel flange of the axle is 1/4" smaller on A-body axles than on the standard 4.5" passenger car axle. On an A-body axle this measures 2", on 4.5" BC axles its 2.25".

This slight difference will cause problems when one attempts to adapt brake systems (drum and backing plate together), or a brake drum from a 4.5" BC axle to a 4" BC axle. If you are using original A-body axles, regardless of what BC is may have been re-drilled for, you can only use the original 10x1.75" drums (re-drill the drums as well).

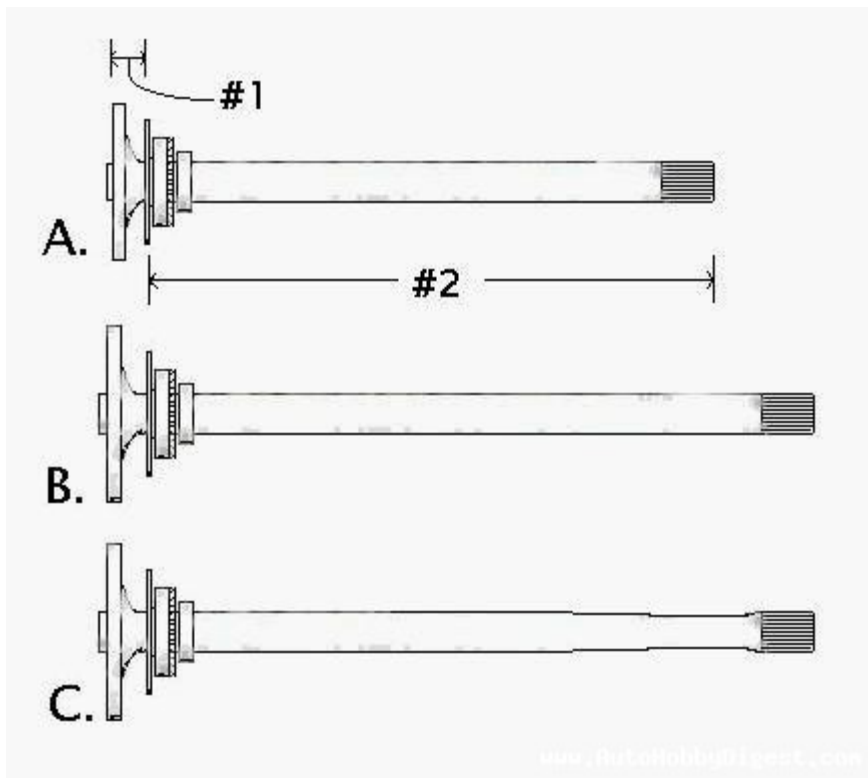

The diagram above illustrates 8-3/4" axles. The top is a 66-72 A-body axle, and the other two are longer axles that generally resemble the B and C-body and truck axles. As Gary wrote earlier, C-body and truck axles can be shortened and re-splined by a quality machine shop, however it is important to note that not all C-body/Truck axles are created equally. The bottom axle illustrates how many mid-60's axles taper as they near the splines, these can not be used as A-body short axle donors! The middle axle shows that at the location of where the new splines will be (26" from bearing retaining plate to the end of the axle, see measurement #2 in the diagram) the outside diameter (OD) must be larger than what the OD of the spline needs to be.

Section 3: Part Numbers and Dimensions of Axles and Housings.

The following chart can be found in the *Mopar Performance Chassis Manual*. The distance between spring perches is an accurate reference, however the *Track* listing is the source of a lot of misconceptions. Track is the distance between the two tires, and includes a proportion of the actual tire track, or patch where it contacts the ground. The chart below tends to lead people to believe that all 62-70 B-body 8-3/4 rear-ends are the same width, *not true!*

Body line	Track	Perches	Notes
A-body, 65-72	55.6	43.0	4" lug bolt circle
B-body, 62-70	59.2	44.0	
B-body, 71-72	62.0	47.3	
B-body station wagon, 71-72	63.4	47.3	
C-body, 64-72	63.4	47.3	
D-body, 64-72	63.4	47.3	
E-body, 70-74	60.7	46.0	

Axle Housing and Axle dimensions

The following is a listing of *flange to flange* widths for various year 8-3/4" housings. This is a measure of the bare housing, with brake backing plates removed, from the outside of the flange across to the outside of the other flange. Chrysler part numbers are listed as well for the purpose of showing a distinction between some housings and axles.

Part#	Application	Flange to Flange Width	Notes
1045744 1945745 2070259 2070269 2070270 2070960	57-62 full-size 63-64 Chrysler/880	55-5/8" (est.)	8-1/4" axles 57-61 have different housing part numbers. SG axle shorter than open rear axle, except for 1964 models.
	65 C-body	unknown	axle 2404228 same as A-100 vans and trucks.
2800175	66 C-body	unknown	
2881003	69 C-body	56-7/16"	
2881310	69 C-body wagon	59-7/64"	
	70 C-body	57-3/4"	
2070231	60-62 Imperial	unknown	Imperials: 57-63 SG, all 64 axle 1829267
2070961	63-64 Imperial	unknown	Imperials: 57-63 open axle 1675449
2404208	65-66 Imperial	unknown	different from above axles, 2404139
2800224	69 Imperial	unknown	

2070539	62-63 B-body 64 Max Wedge	53-1/4"	<ul style="list-style-type: none"> • Parts Manuals list four different axles for this housing: • 2070573 - 741 case w/o SG 30-1/2" overall; • 2404003 - 742 case w/o SG 30-1/2" overall; • 2070695 - 741 case SG 30-7/16" overall; • 2404050 - 742 case SG 30-7/16" overall;
2404271	64 B-body <i>except Max Wedge.</i>	55-5/8" (est)	1/8" - 1/4" narrower than 2070270 (full-size Chrysler) housing. axle length 31-1/2" overall.
2404143	65 B-body	54-1/2"	uses axle 2404223
2643409	66-67 B-body	54-1/4"	
2852838	68-69 B-body	54-15/16"	<i>same as 1970 B-body, 1/32" difference</i>
3432295	70 B-body	54-29/32"	<i>same as 1968-69 B-body, 1/32" difference</i>
3507502	71-73 B-body	57-47/64"	
3507501	71-73 C-body 71-73 B-body SW	59-1/8"	
2800227 3432647 3432295	66-72 A-body	52-13/64" (70-71) 52-37/64" (72)	4" bolt circle, used 10x1-3/4" drums. <i>These dimensions come from 1970,71,72 Factory Parts Manuals</i>
2852882	70-74 E-body	56-7/16"	

Section 4: 8-1/4" Carrier Housing

From 1957 to 1964 Chrysler manufactured a front loading center section similar to an 8-3/4". Its ring gear diameter was 8-1/4". This is not related to the Spicer built 8-1/4" rear-end used in Chrysler products in the Seventies. The 57-64 was more or less designated as the six cylinder rear-end whereas the 8-3/4" was designated for V-8 cars. The 57-62 8-1/4" used a case with a casting number 1828448. It appears that in 1963 and 1964 this gear set was installed in a 741 case. The 1828448 may have used a different housing flange pattern as it calls for a different housing (1045744,2070269). These rear-ends were for extreme light duty and were only used in six cylinder applications. six cylinder station wagons used 8-3/4"s. Along other available gear ratios, there was a 3.31:1 for manual transmissions and a 2.93:1 for automatic transmissions.

Section 5: Aftermarket Components

Auburn Gear limited-slip differential is available new from Auburn Gear. This unit is essentially the same design as the factory 68-74 Borg-Warner Spin Resistant unit, however Auburn Gear continues to make engineering improvements. Like the original design, the new unit is non-re-buildable. It can, however, be used with all 8-3/4" housings so long as 69-74 differential bearing cones and cups are used. AG Part No. 542051.

Detroit Locker limited-slip, or "No Spin", differentials are also available. The origins of these heavy duty units dates back to Ford Motor Company's racing program of the Sixties. Tractech manufactures the Detroit Locker with some improved streetable features. Tractech's Part No. 187SL-14A.

Powertrax Locker is a small drop-in locking differential that replaces the spider gears in an open differential housing. Two versions are available: a street friendly *Lock-Right* model and the beefier *Performance Locker*. Powertrax Part No. 1240 and VX124A (respectively).

Green Bearing Company builds a bearing kit that replaces the cone-type wheel bearings. These are sealed roller bearing units that do not require end play adjustment, however they offer no side to side support, and fail quickly in street applications. These are drag race bearings only (the manufacturer even lists them under the "Racing" segment of their catalog). Green Part No. RP400.

Part II, Appendix B: Torque Reference

Fastener	Foot-Pounds
Axle Shaft Nuts (tapered axle end nuts)	145 (min)
Brake Support Plate to Housing Mounting Bolt Nuts	30 to 35
Differential Carrier to Axle Housing Bolt Nuts	45
Rear Axle Drive Gear to Case Bolts	60
Differential Bearing Cap bolts	90
Rear Axle Drive Pinion Companion Flange Nut	240 (min)
Rear Spring "U" Bolt Nuts	50

Source: 1963 FSM

Part II, Appendix B: Tapered Axle

see tech article [Tapered Rear Axles](#).

Part II, Appendix C: OE Ring and Pinion Sets

Tooth Count	Ratio	Carriers
41-14	2.93	'448', '657', '741', '742', '489'
41-13	3.15	'448', '657', '985',
35-11	3.19	'448', '657'
	3.23	'741', '742', '489'
43-13	3.31	'448' (57-61), '741' (62-63)
37-11	3.36	'448', '657'
39-11	3.55	'448', '657', '741', '742', '489'
41-11	3.73	'448', '657', '985', '741'
43-11	3.91	'448', '657'

References

- Chrysler factory service manuals, various, 1964-1974.
- Chrysler parts catalogs, various, 1957-1974.
- Hollander Interchange Manuals, 40th edition.
- Mopar Performance catalogs.
- Mopar Performance Chassis Manual.
- Mopar Performance Oval Track Manual.
- Mopar Action magazine, selected articles.
- High Performance Mopar magazine, selected articles.
- Chrysler Car Enthusiast, Engines, Etc magazine, selected articles.
- BCA/National catalog # 510-1, 1995.
- Chicago Rawhide (CR) Seals & Bearings catalog # 457205, 1991.
- American Bearing catalog # 710, 1980.
- Fel-Pro Master Gasket Catalog, # 900-96, 1/1996.
- Precision Universal Joint catalog # MC-86, 1/1986.
- TRW Universal Joints catalog # X-4003, 1995.
- Mopar Mailing List (MML) postings.
- Memory.